

12047946
C307

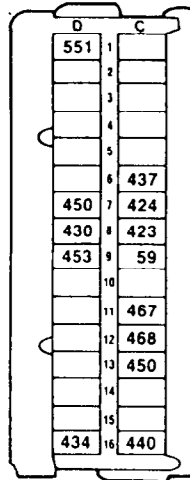

12045575
C310

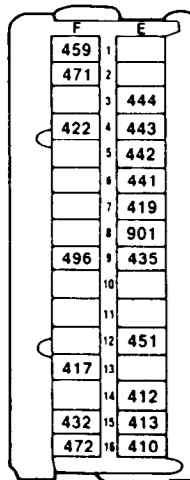

12052052
C311

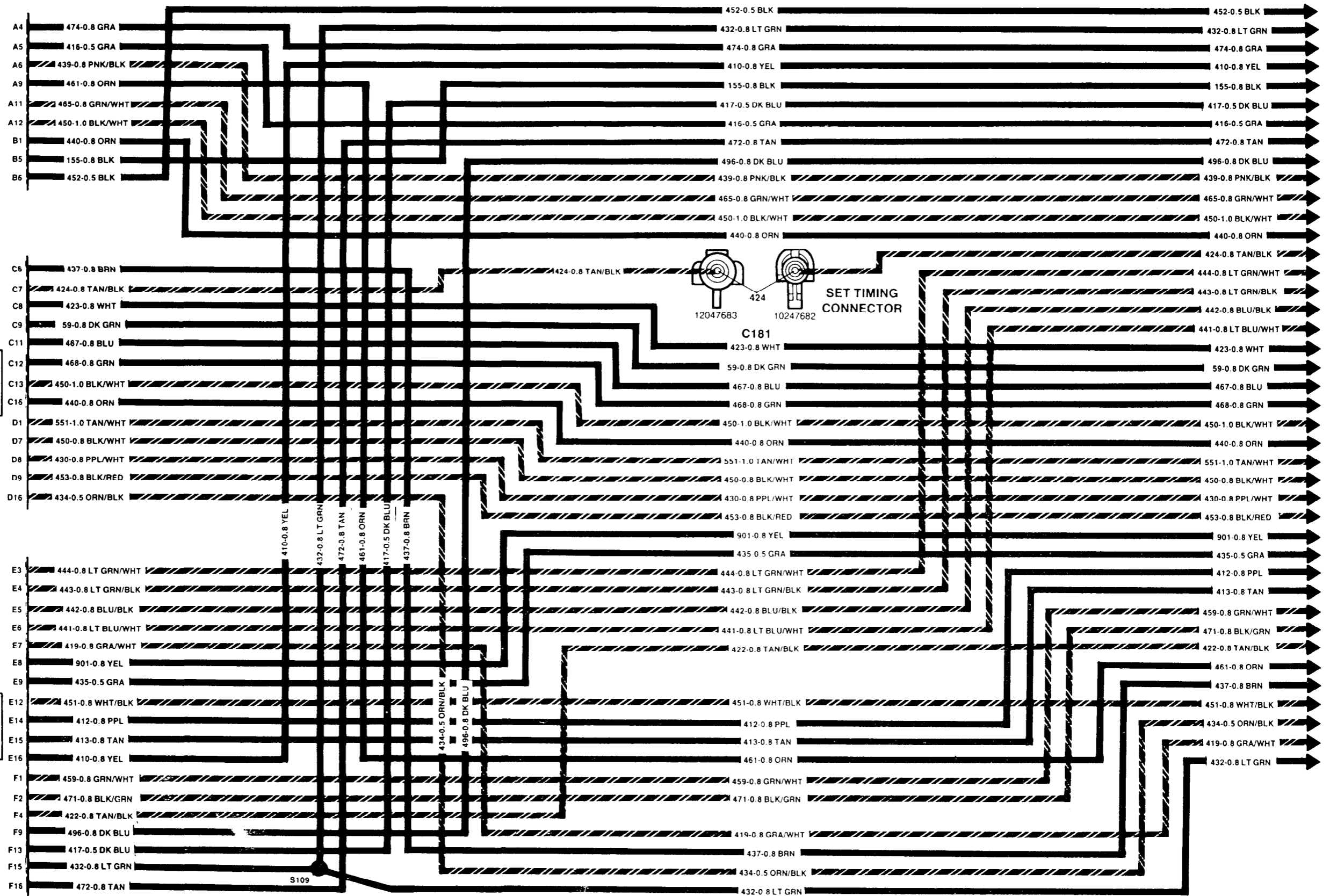

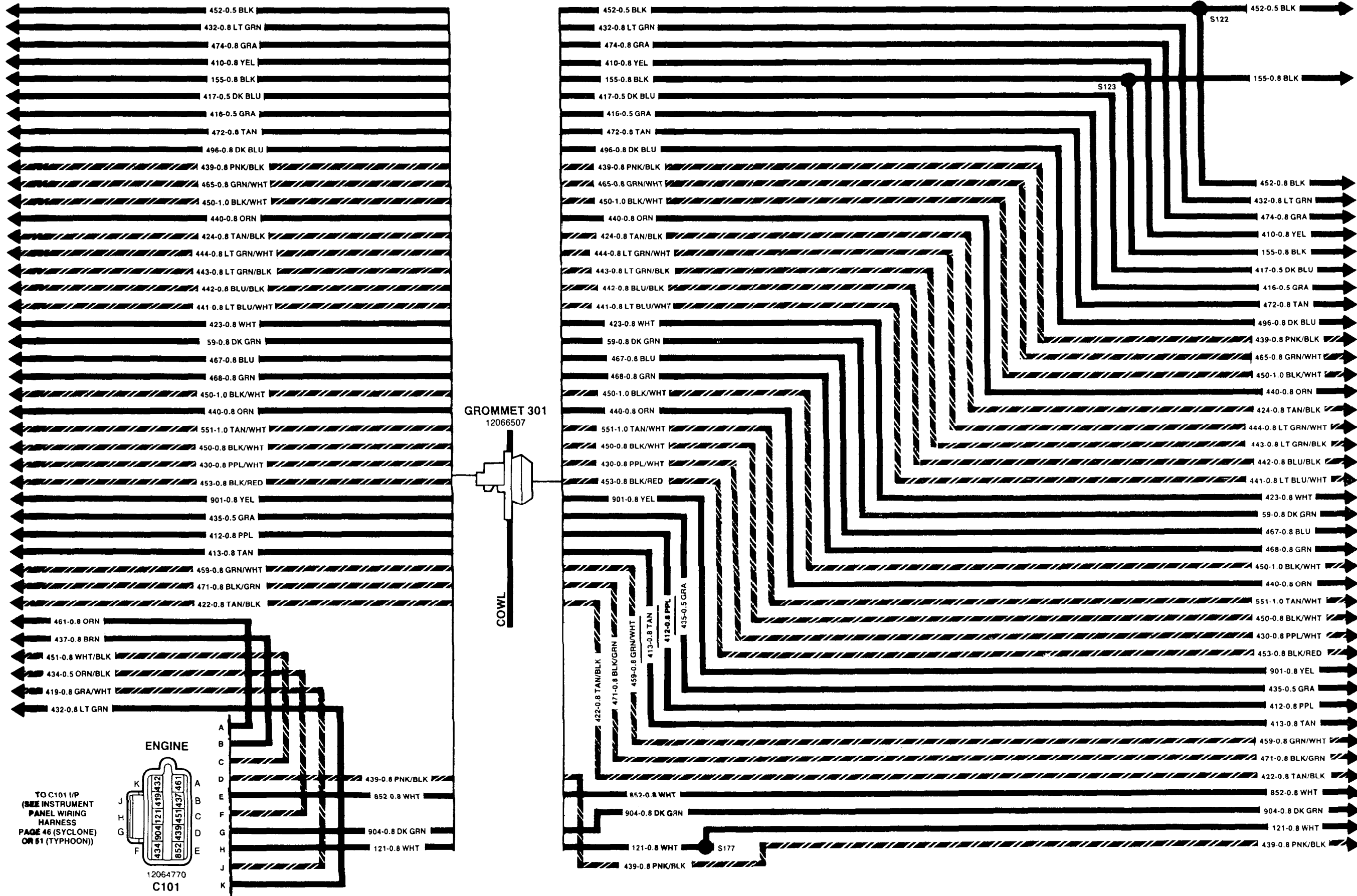

38 ENGINE WIRING HARNESS (SYCLONE/TYPHOON)

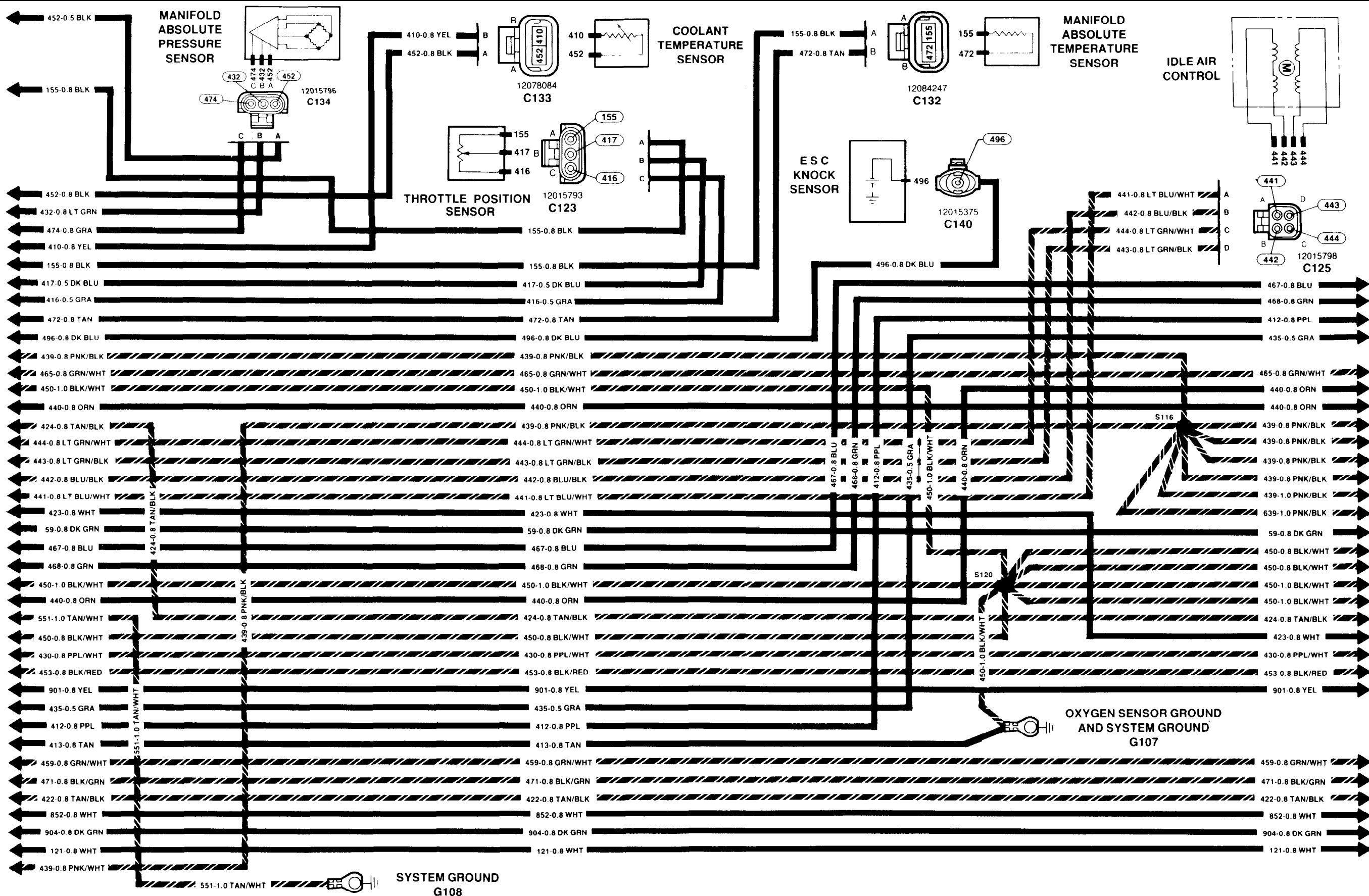

ENGINE WIRING HARNESS (SYCLONE/TYPHOON) 39

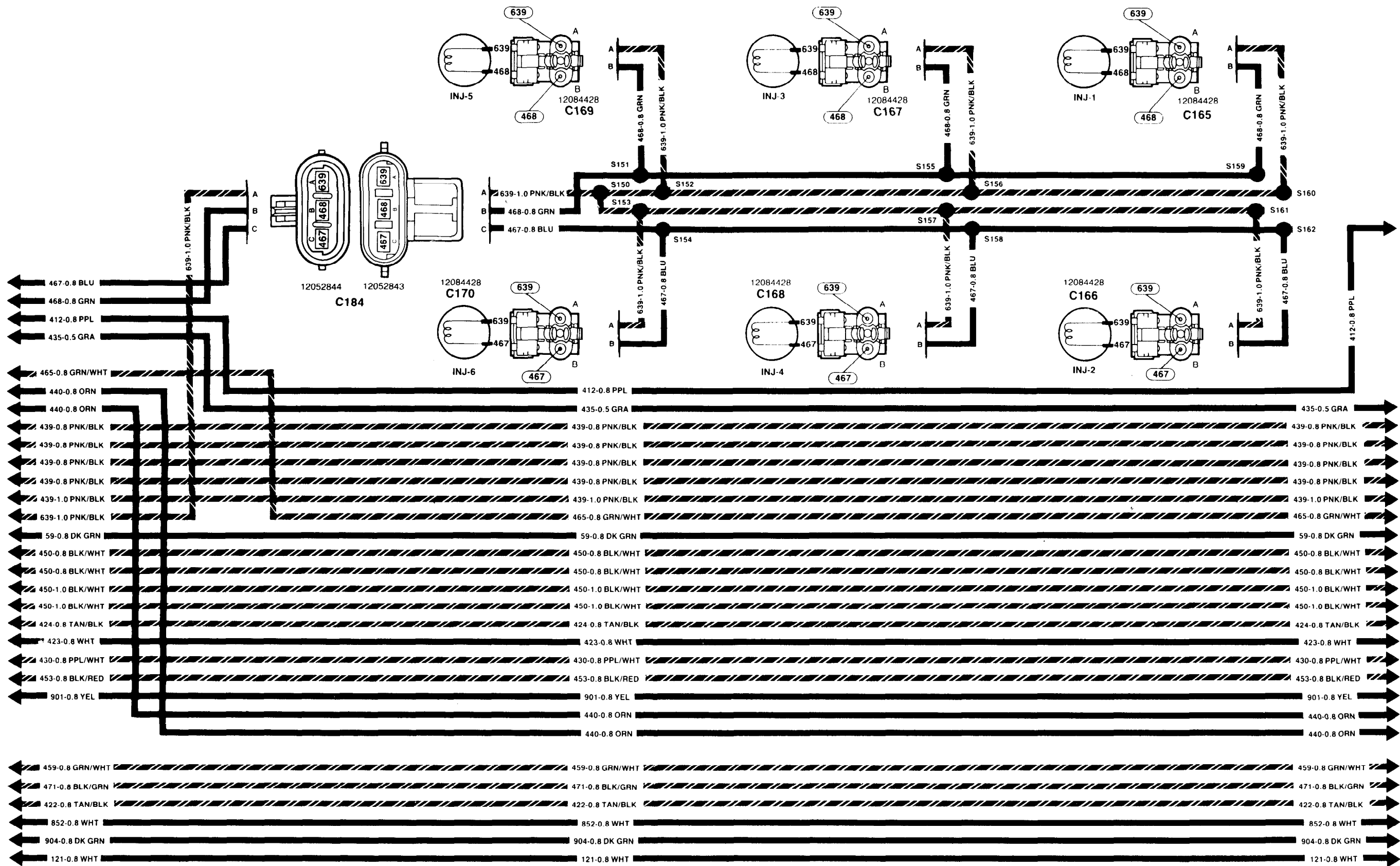

40 ENGINE WIRING HARNESS (SYCLONE/TYPHOON)

WASTE GATE SOLENOID

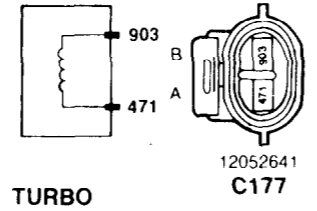

TURBO COOLANT LEVEL SENSOR

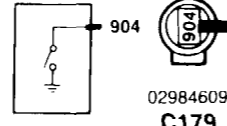

TURBO BOOST RELAY CUT-OUT

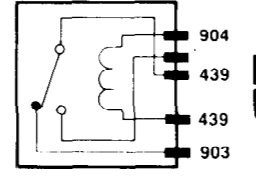

CHARGE AIR COOLER PUMP CONTROL RELAY

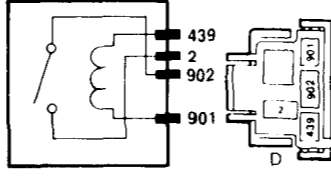

DISTRIBUTOR

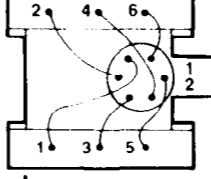

CHARGE AIR COOLER PUMP

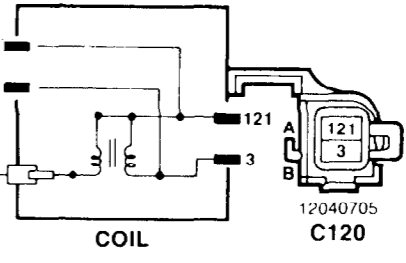
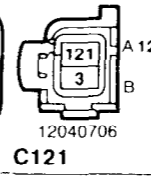
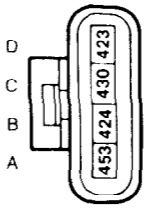
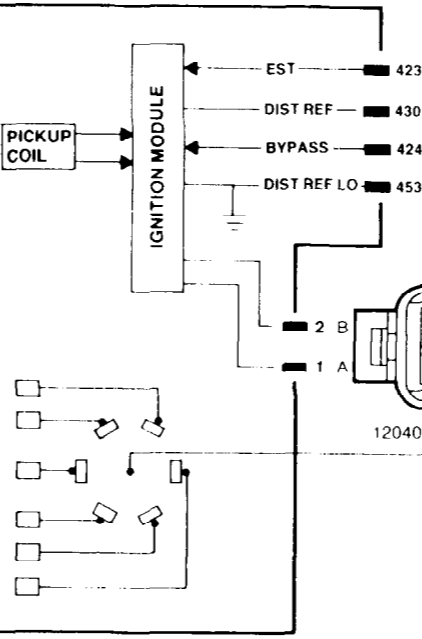
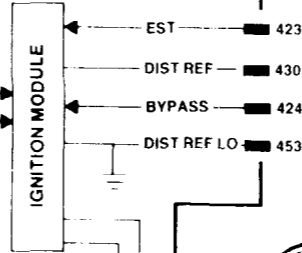
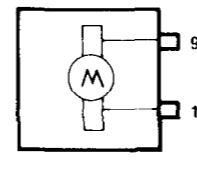

HEATED OXYGEN SENSOR

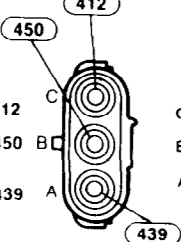

EGR VACUUM REGULATOR VALVE SOLENOID

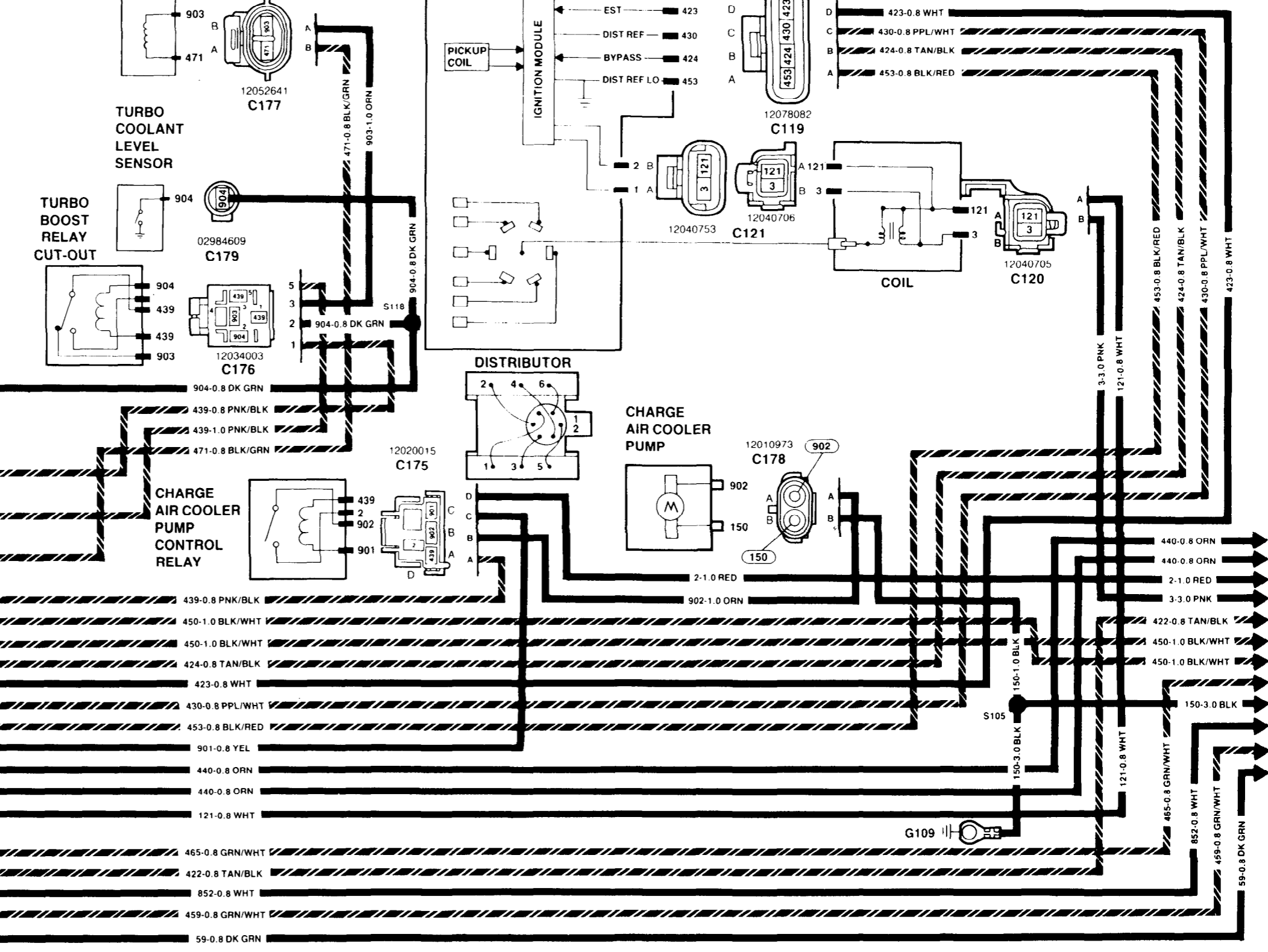
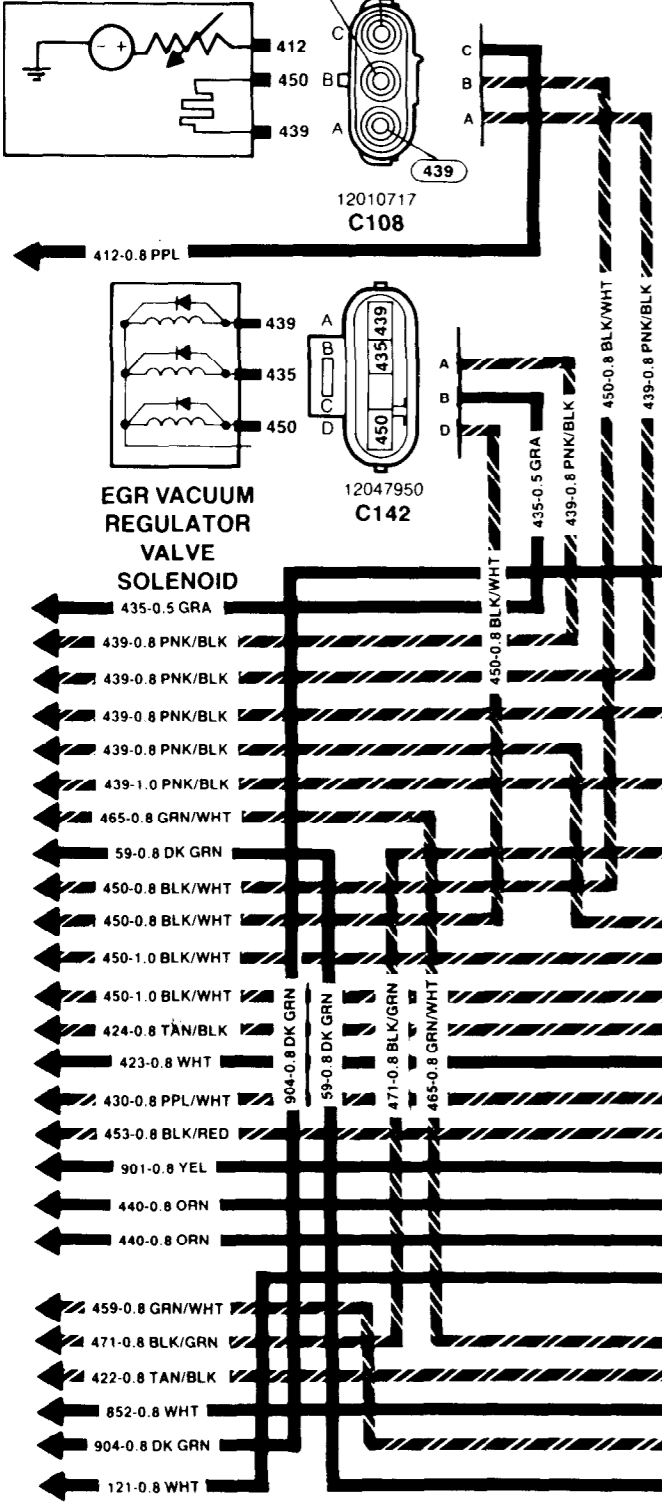
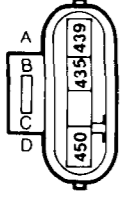

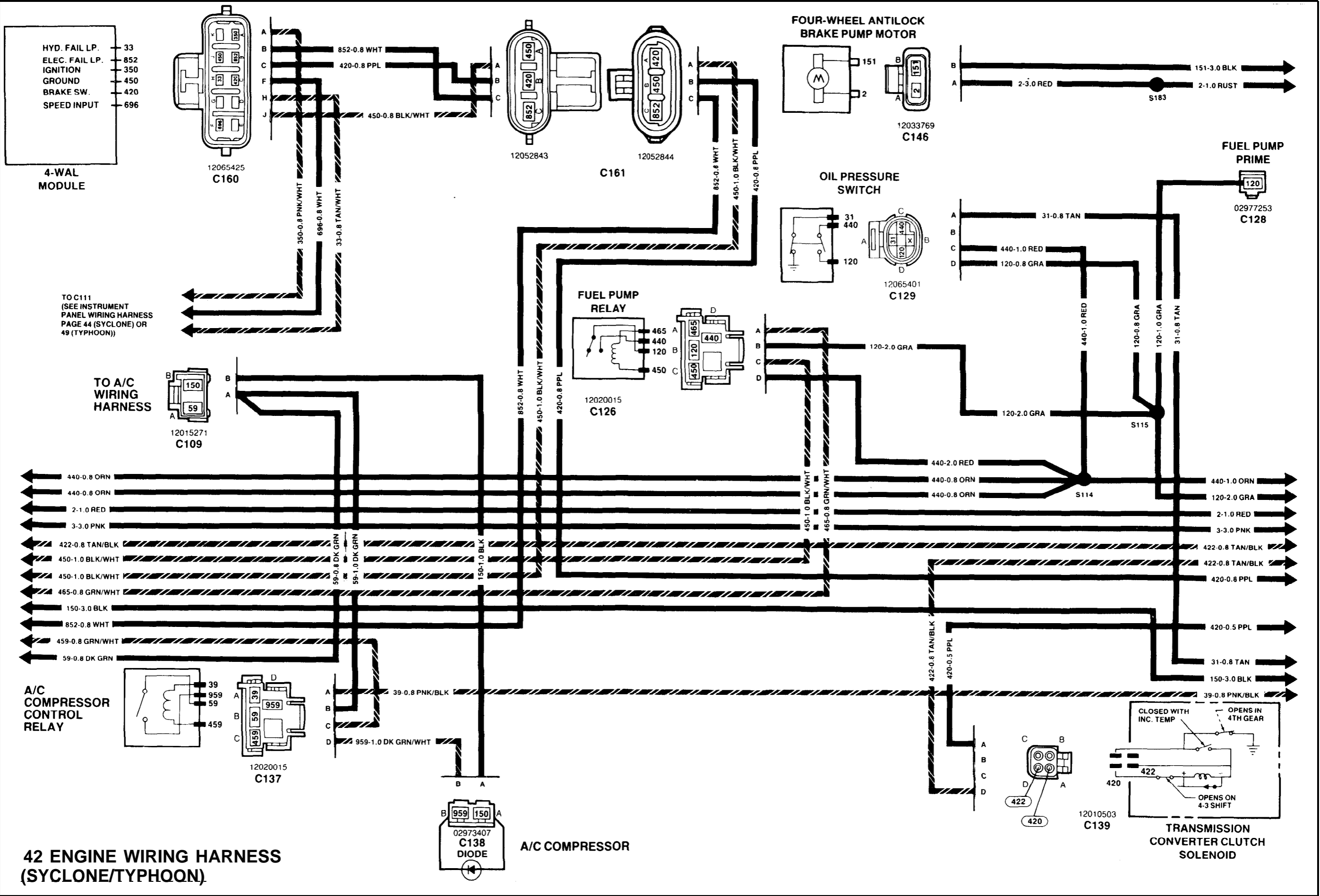

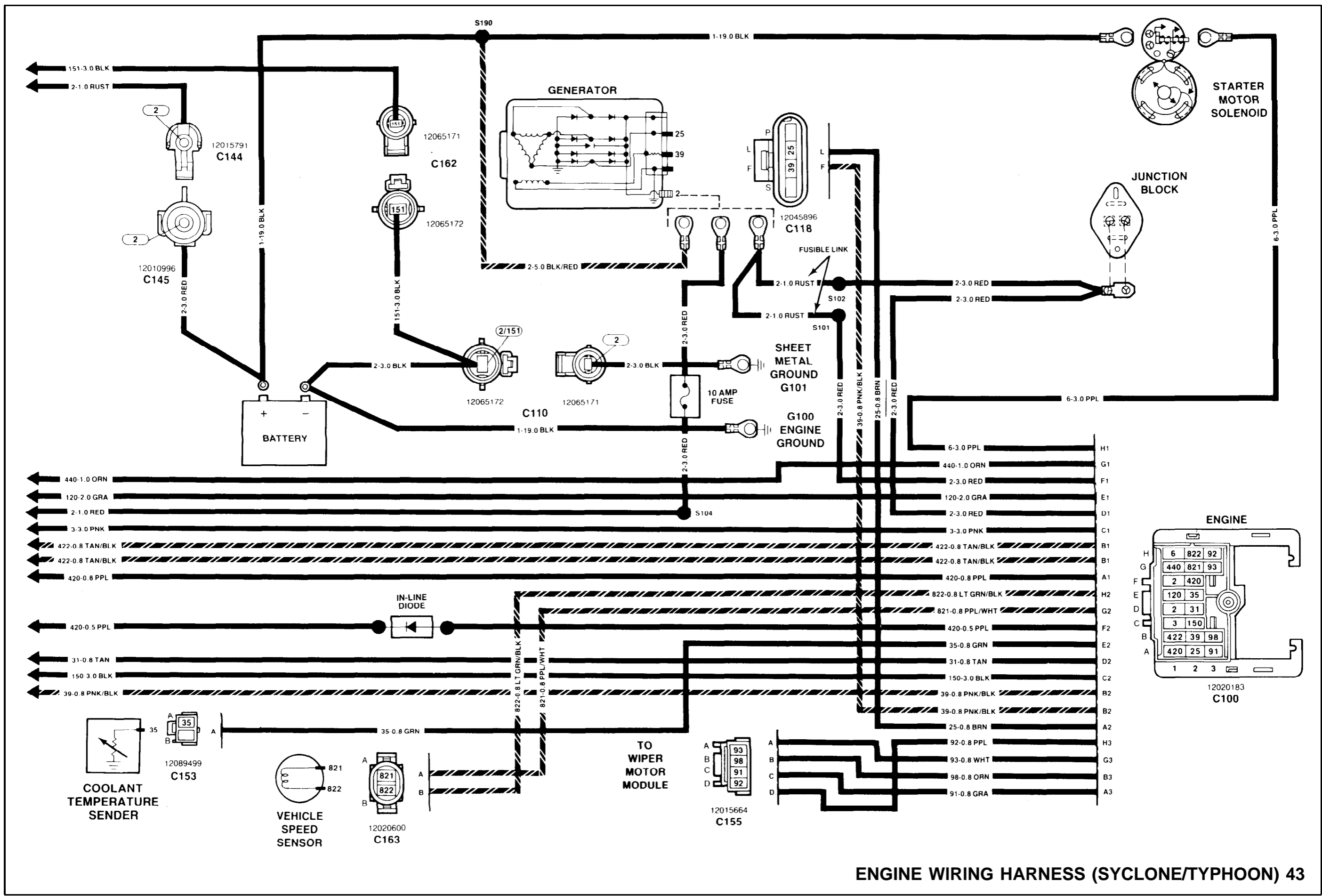

ENGINE WIRING HARNESS (SYCLONE/TYPHOON) 43

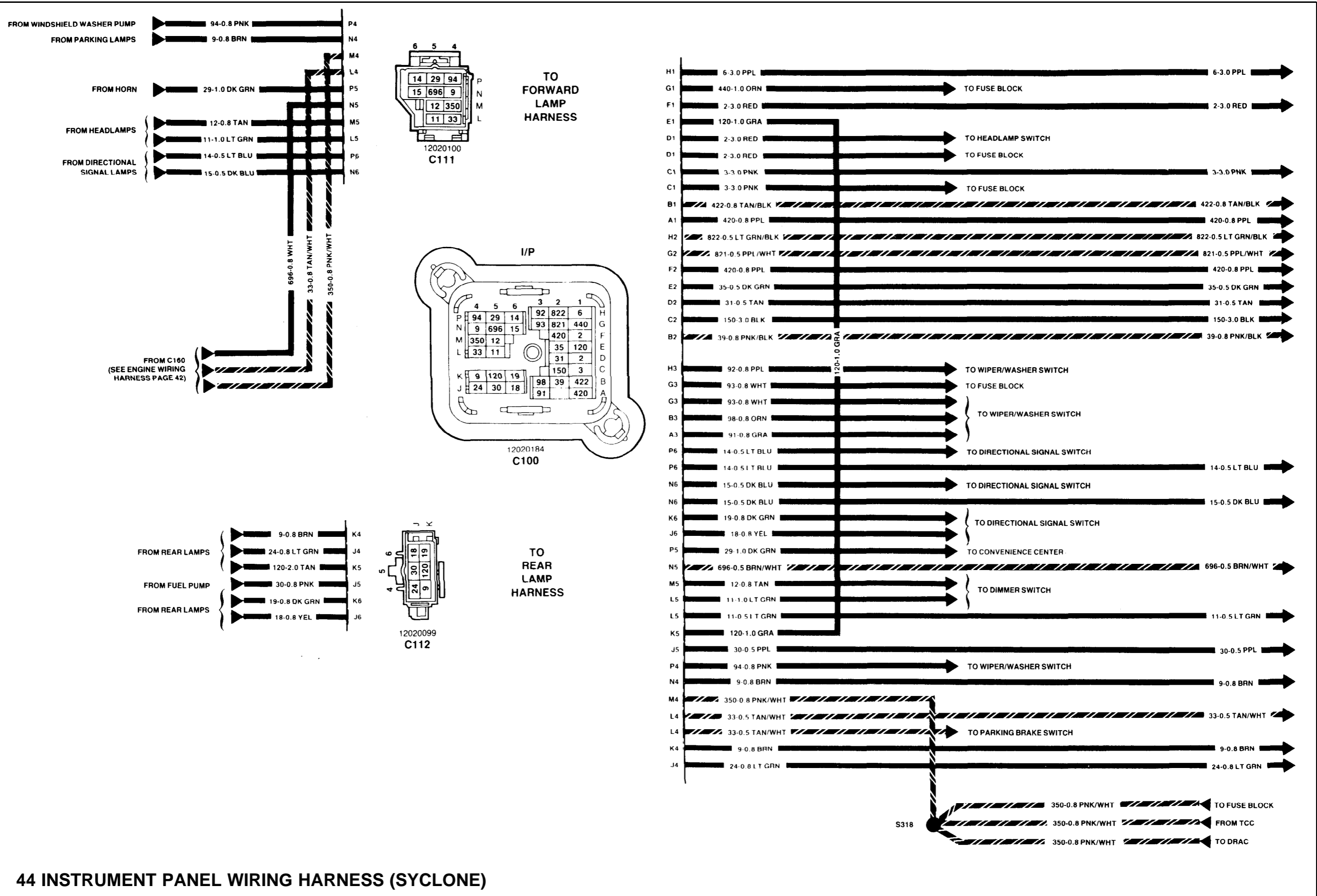

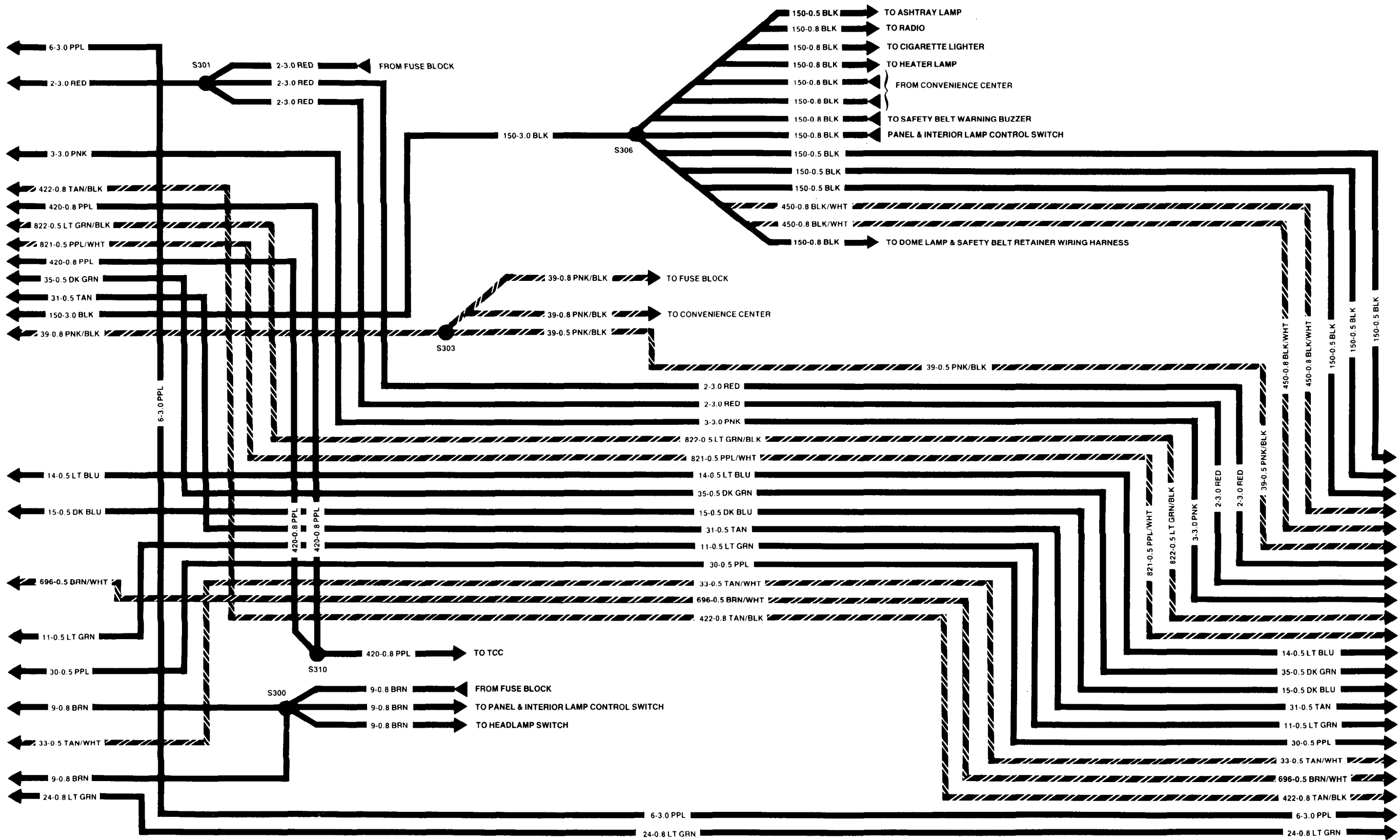

INSTRUMENT PANEL WIRING HARNESS (SYCLONE) 45

FROM
C101 ENGINE
(SEE ENGINE
WIRING HARNESS
PAGE 38)

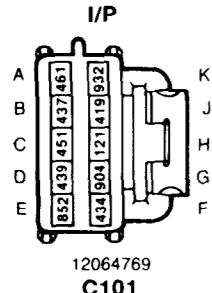

**IGNITION
SWITCH
C301**

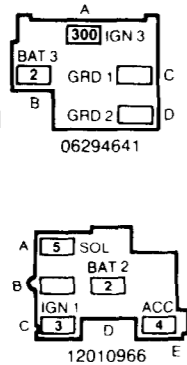

DRAC

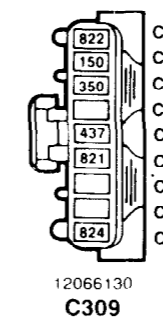

FROM FUSE BLOCK

FROM S318
(SEE PAGE 44)

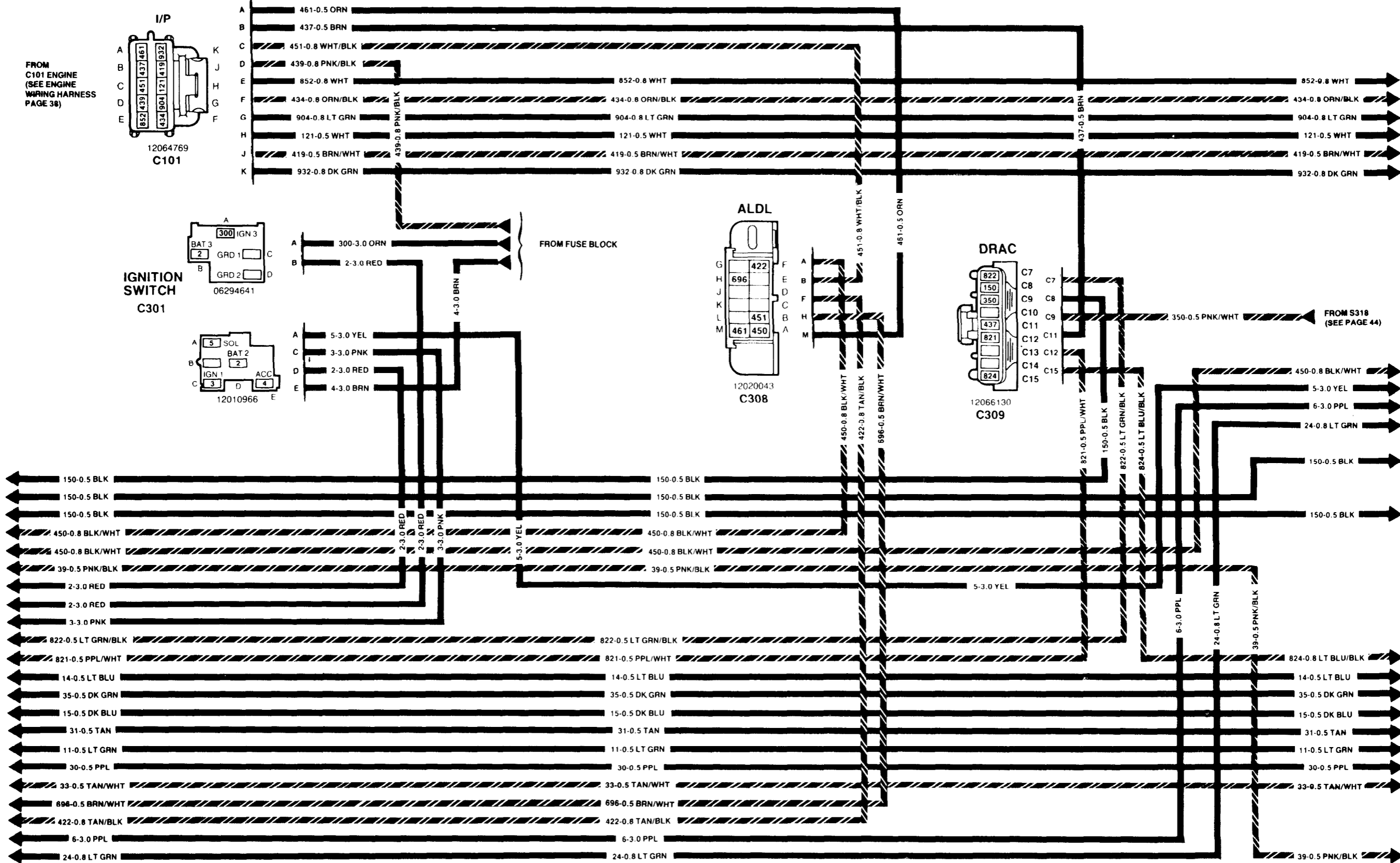

46 INSTRUMENT PANEL WIRING HARNESS (SYCLONE)

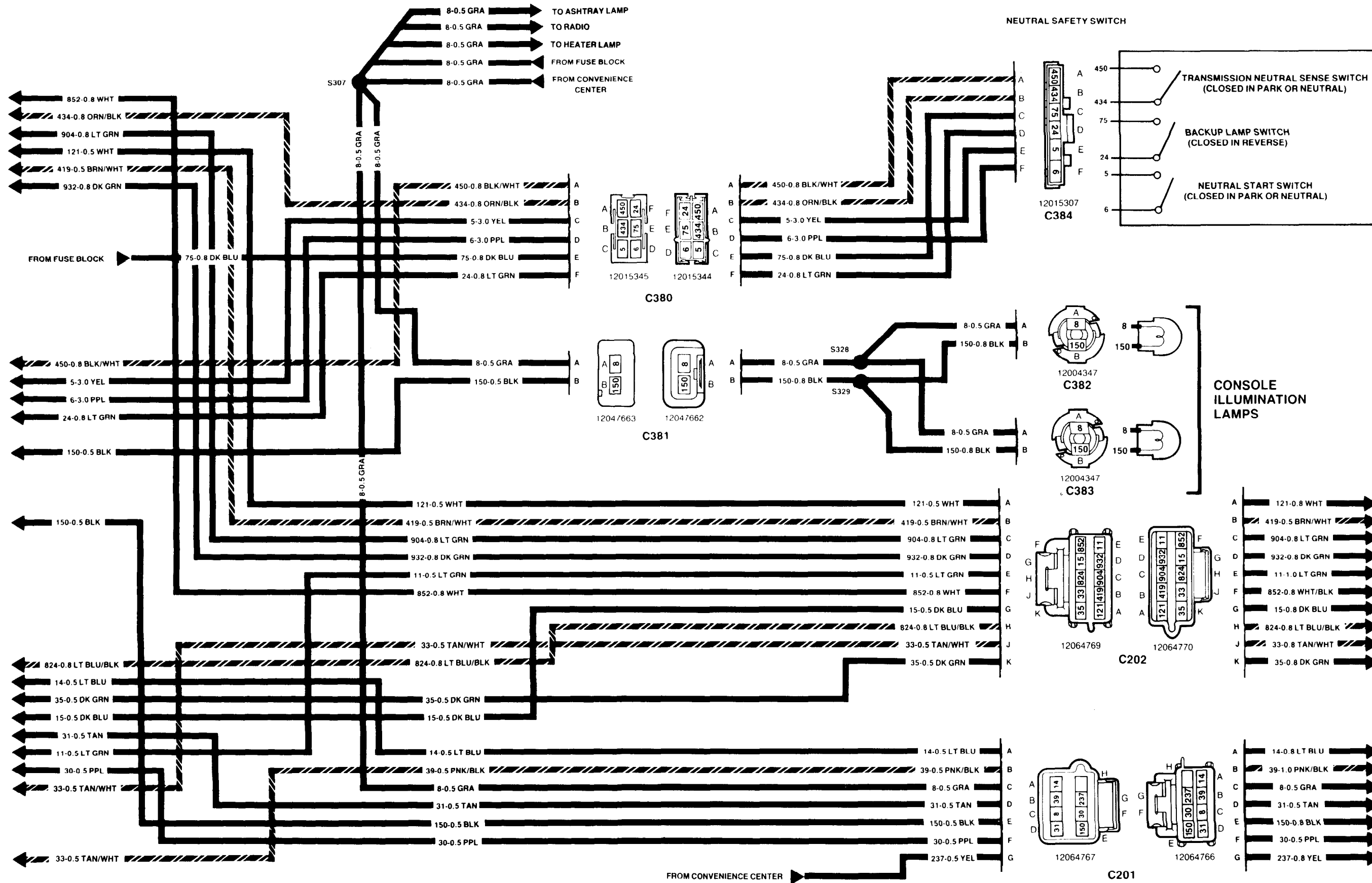

INSTRUMENT PANEL WIRING HARNESS (SYCLONE) 47

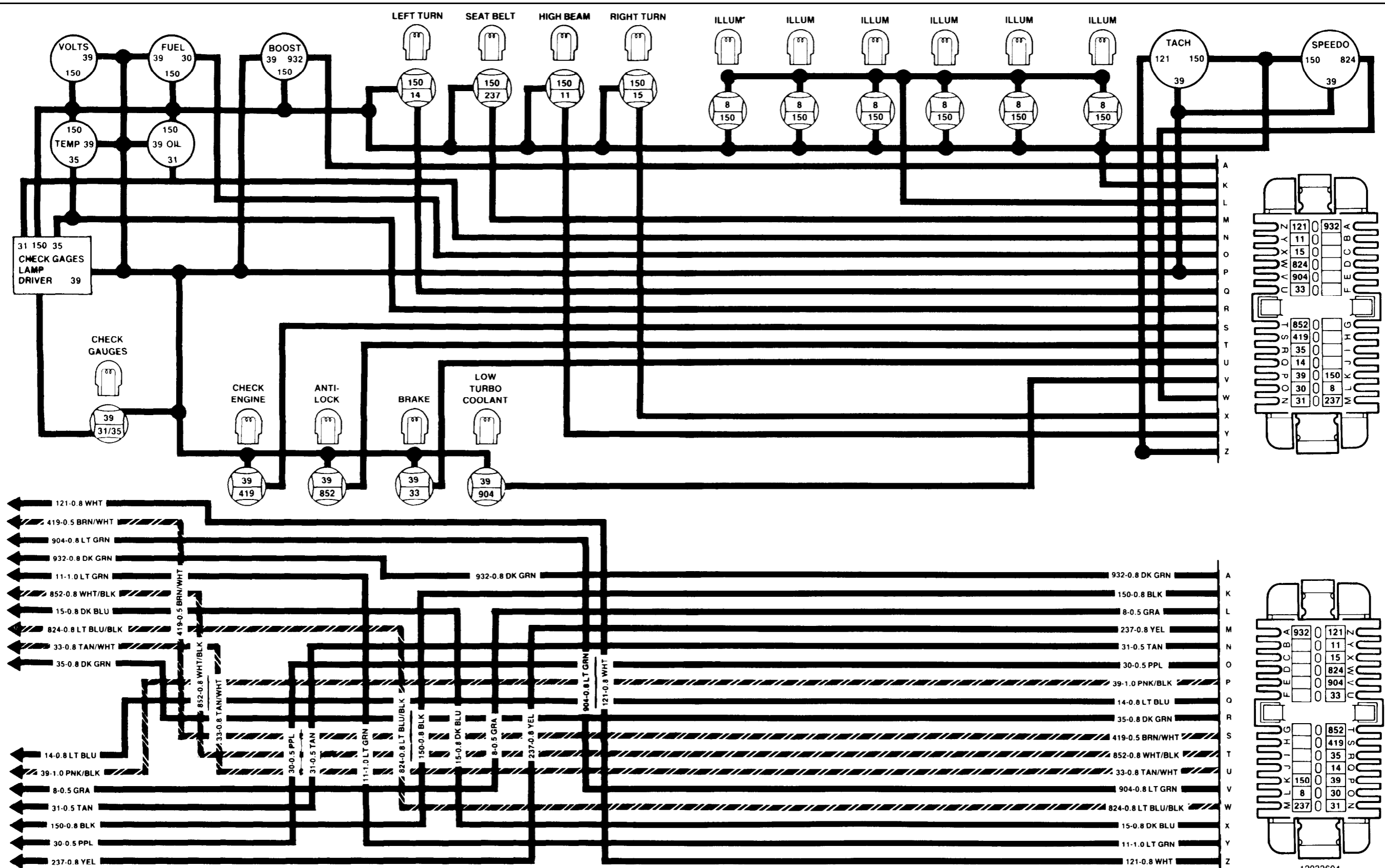

48 INSTRUMENT PANEL WIRING HARNESS (SYCLONE)

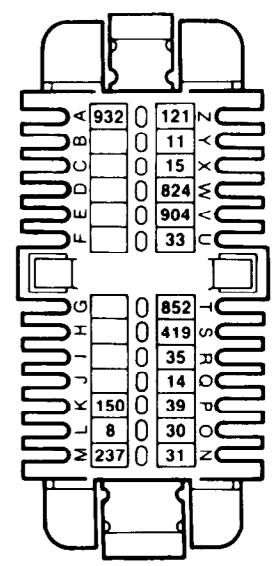
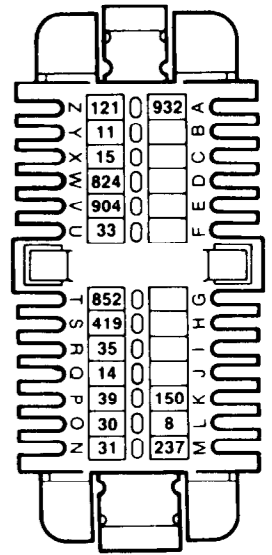

12033604
C200

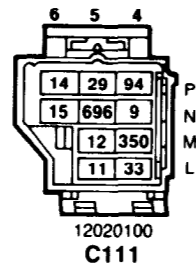
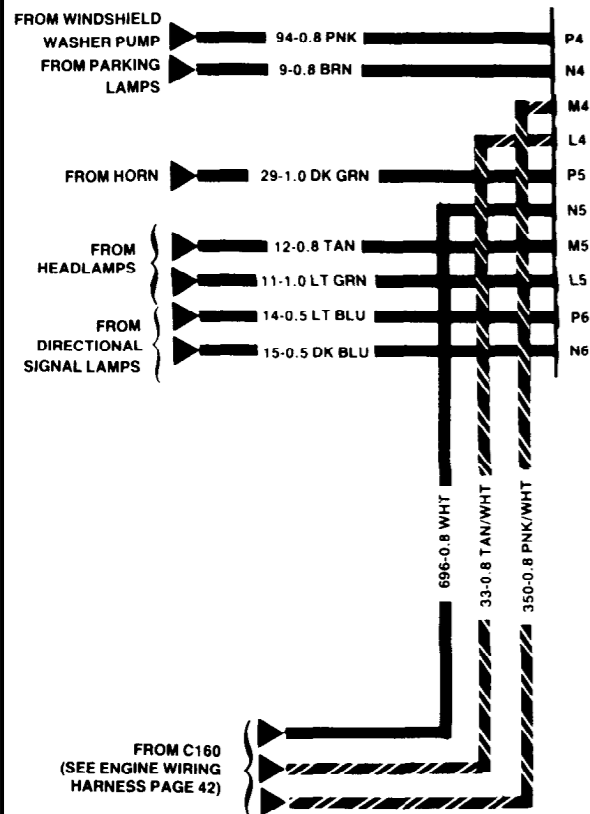

TO FORWARD LAMP HARNESS

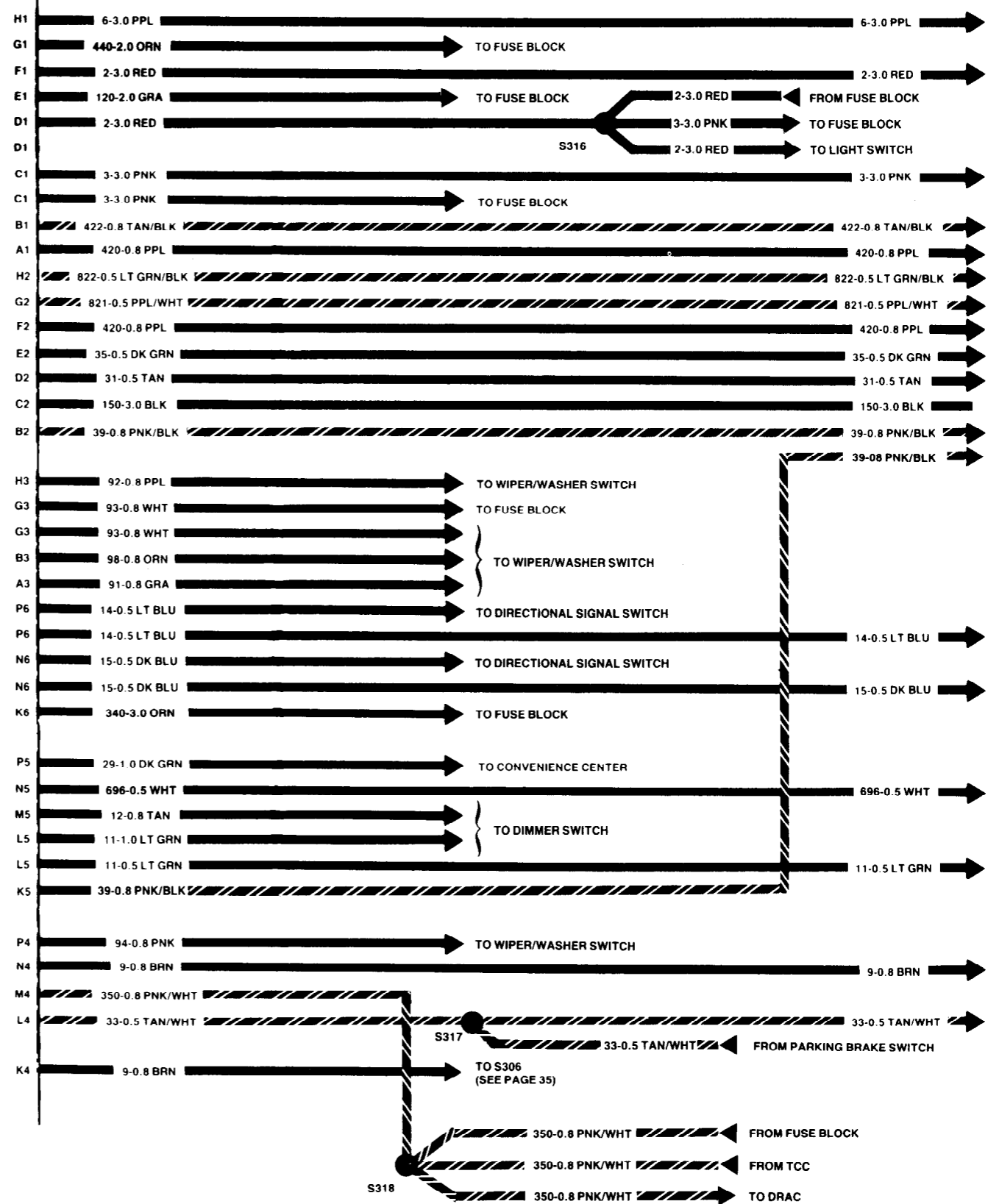
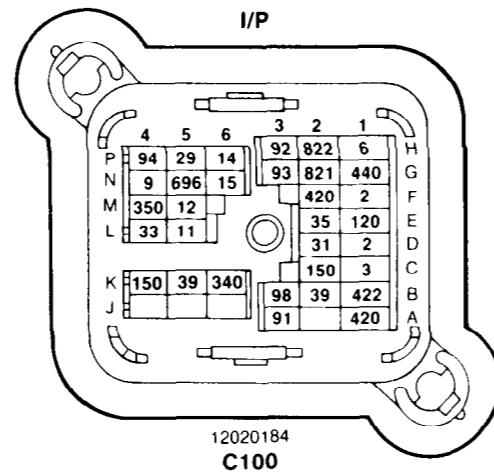

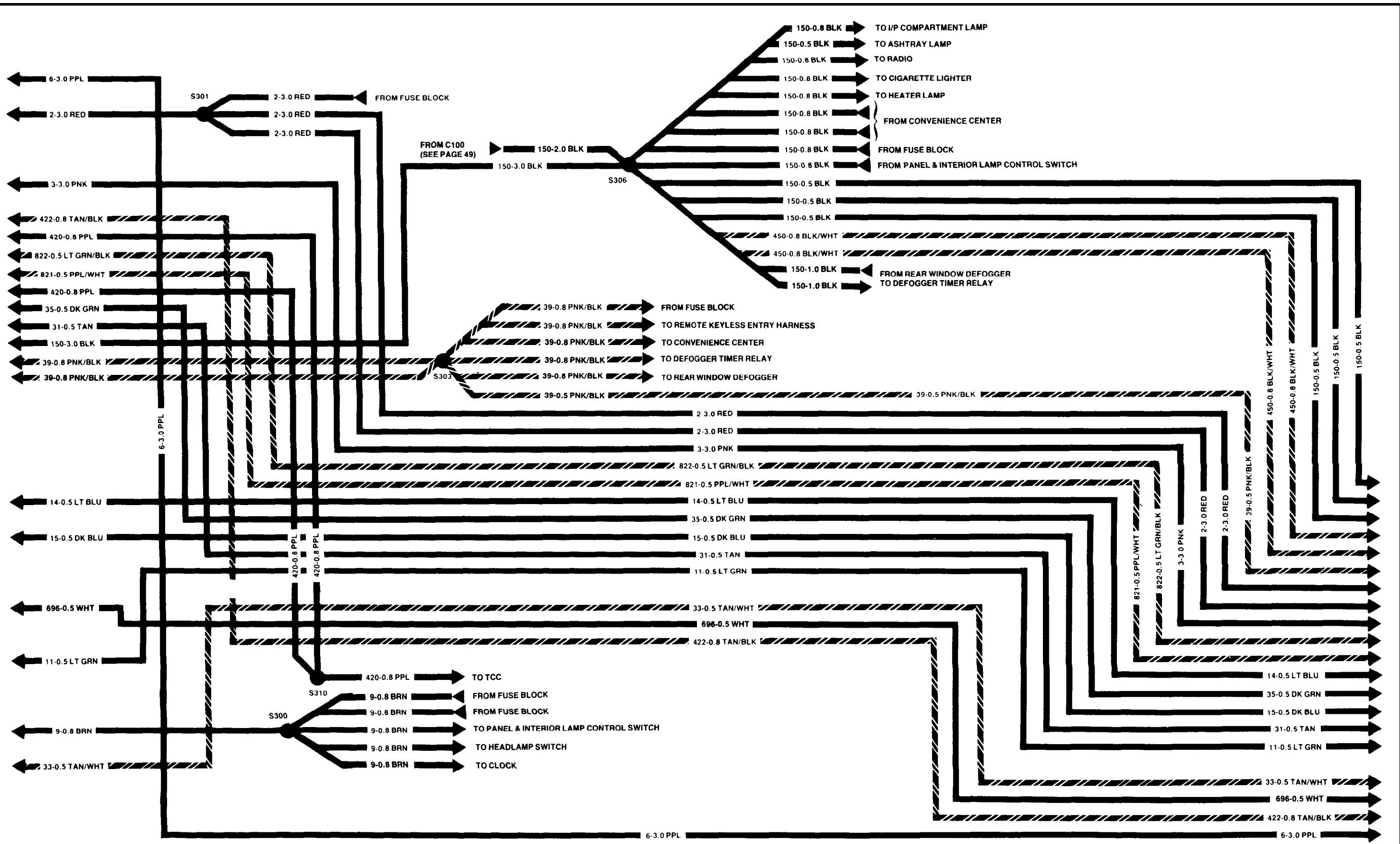

50 INSTRUMENT PANEL WIRING HARNESS (TYPHOON)

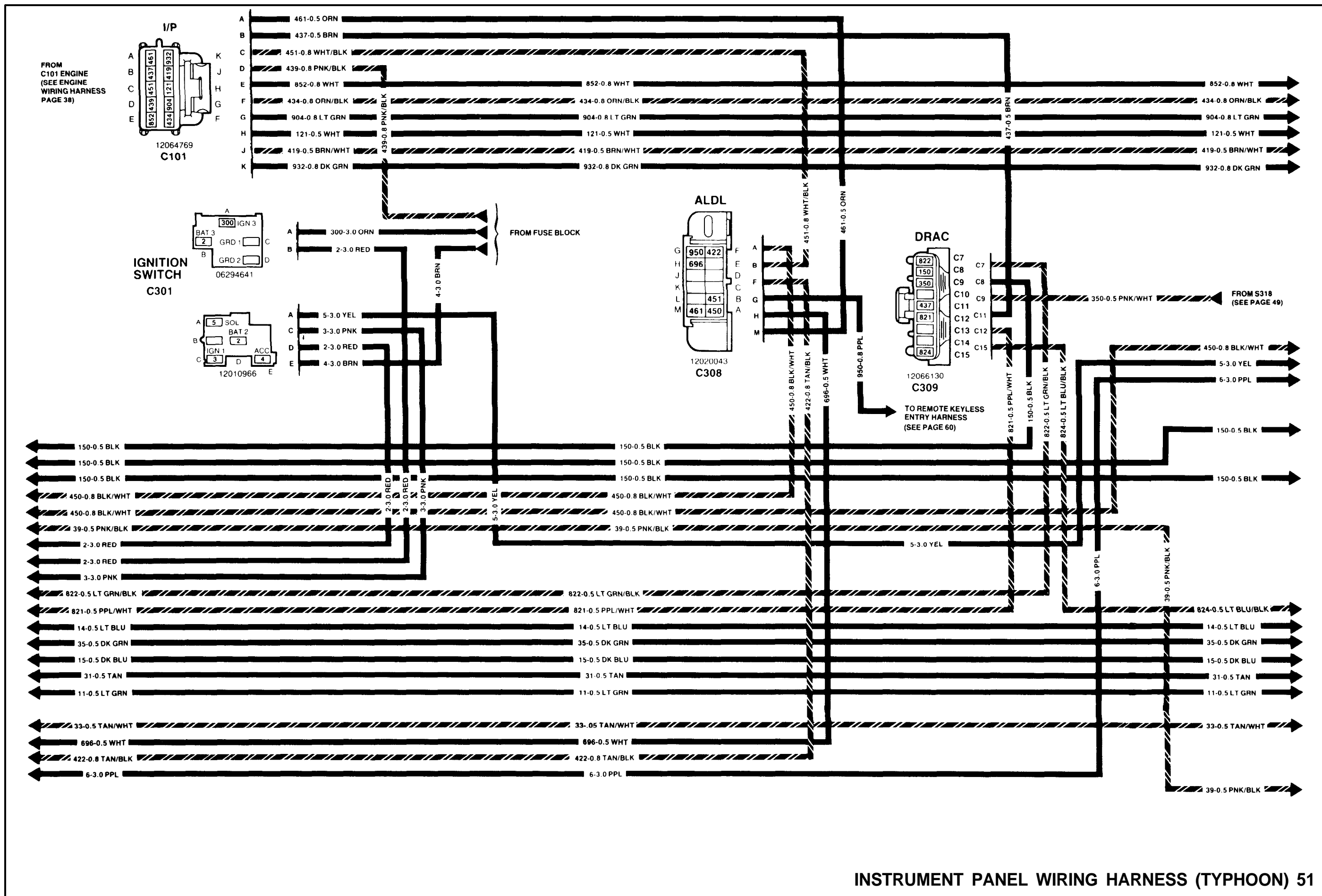

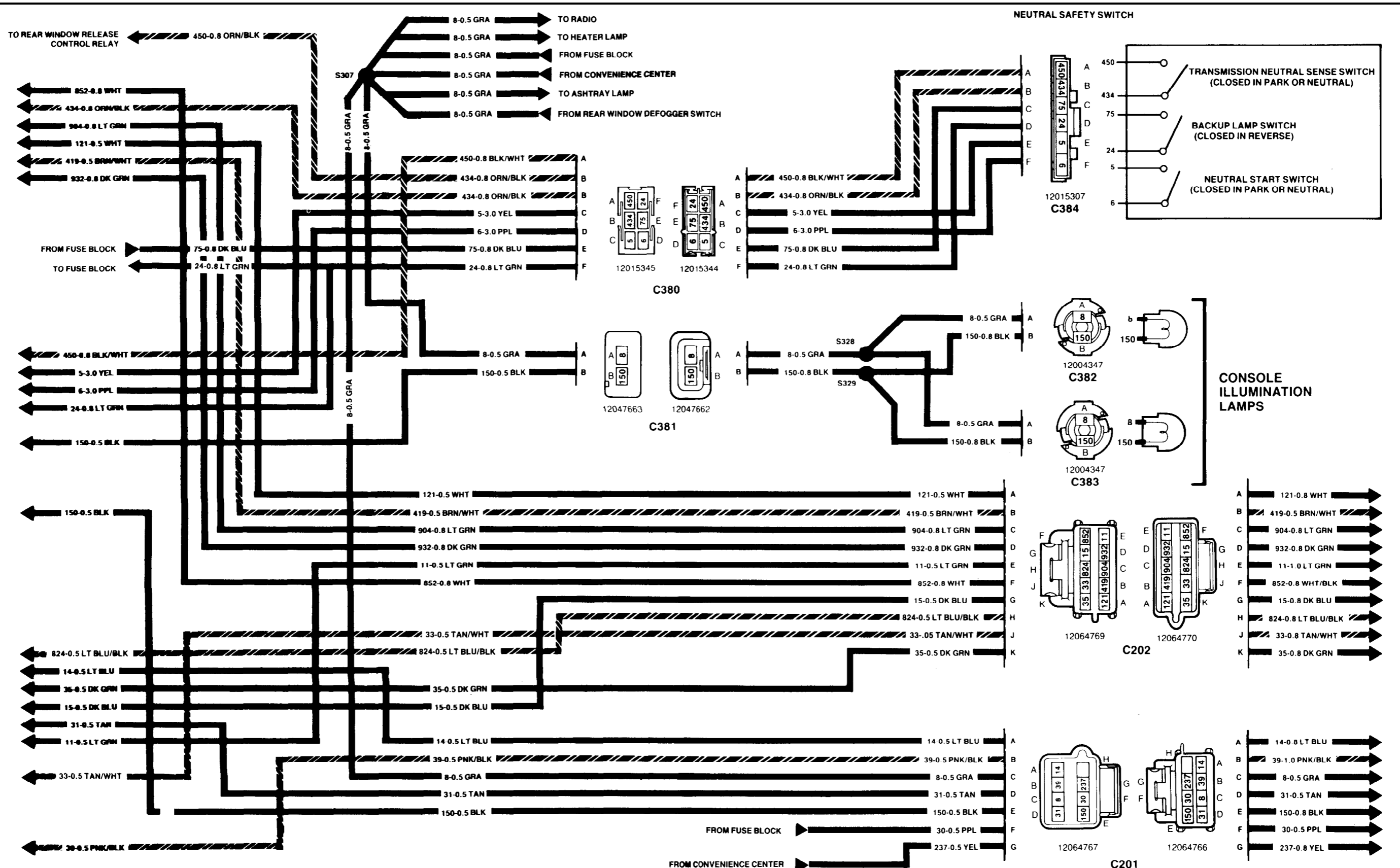

52 INSTRUMENT PANEL WIRING HARNESS (TYPHOON)

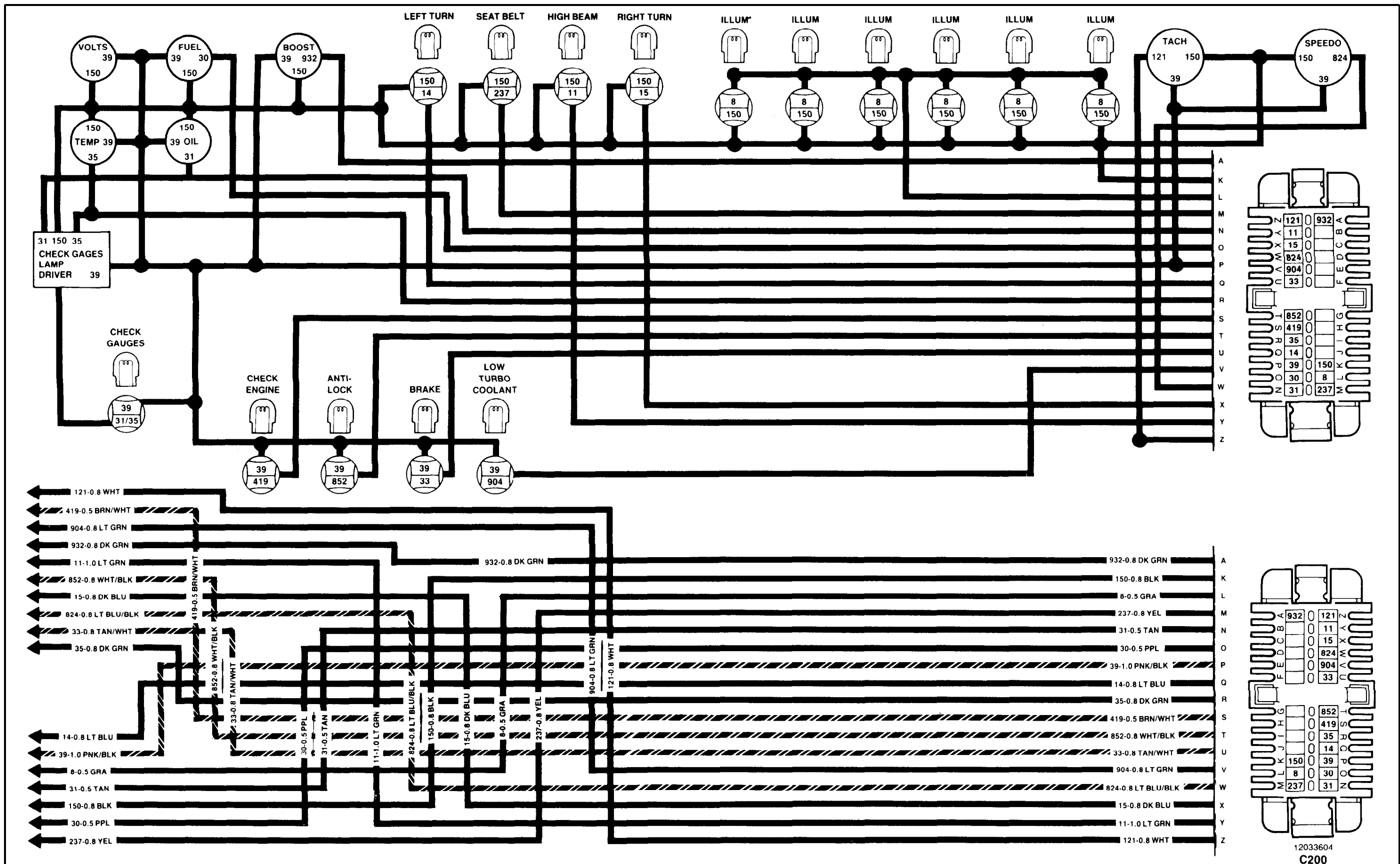

INSTRUMENT PANEL WIRING HARNESS (TYPHOON) 53

12033604
C200

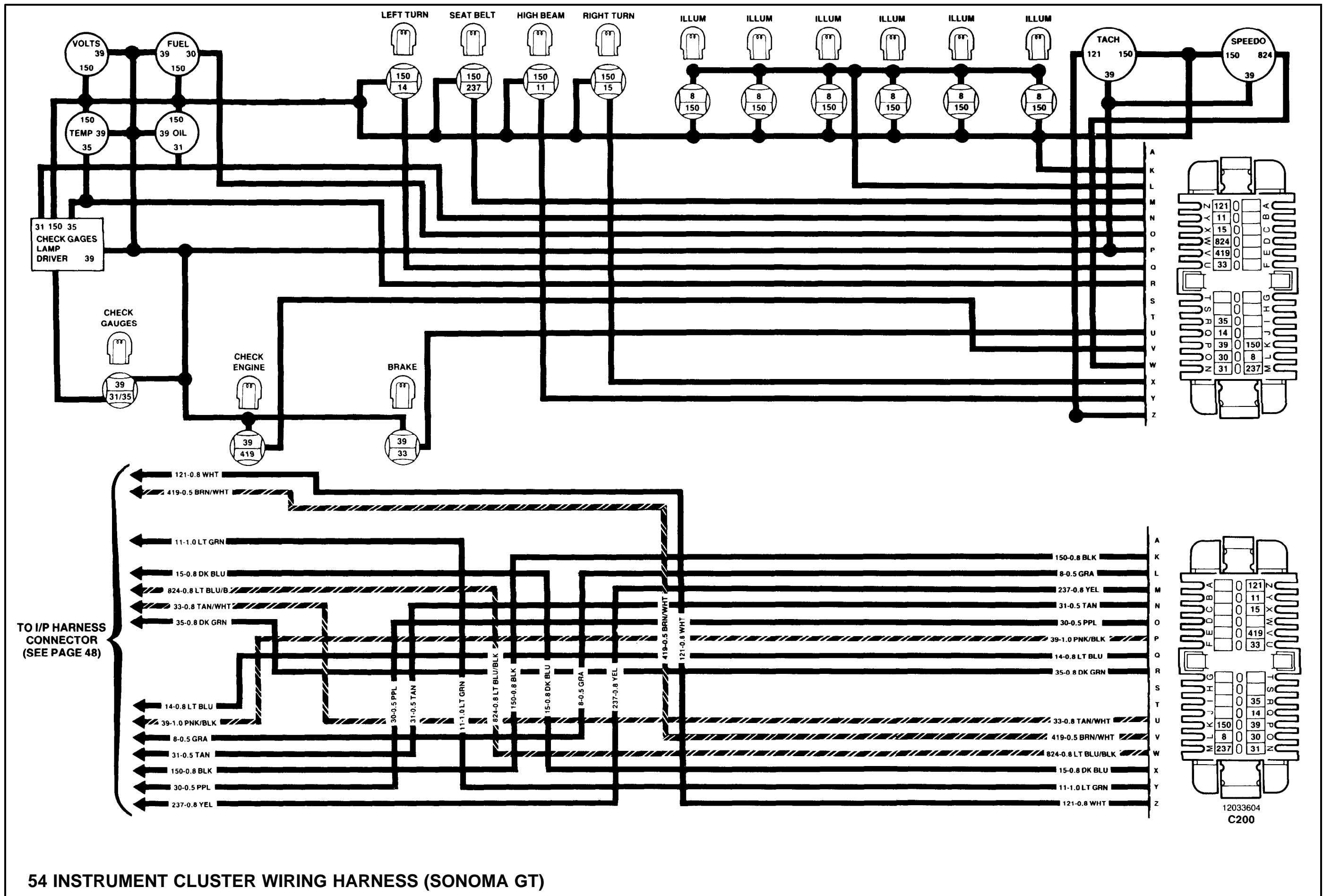

54 INSTRUMENT CLUSTER WIRING HARNESS (SONOMA GT)

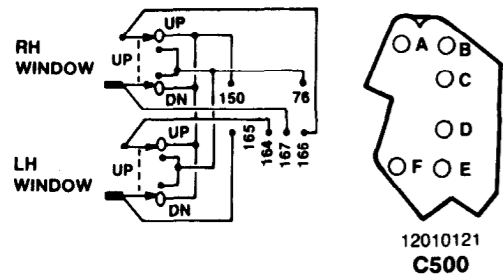

LH POWER WINDOW SWITCH

LH POWER WINDOW MOTOR

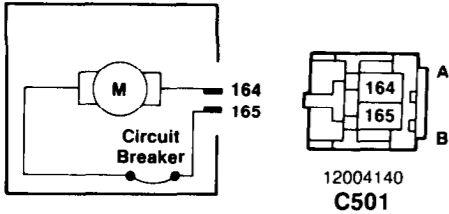

LH POWER DOOR LOCK SWITCH

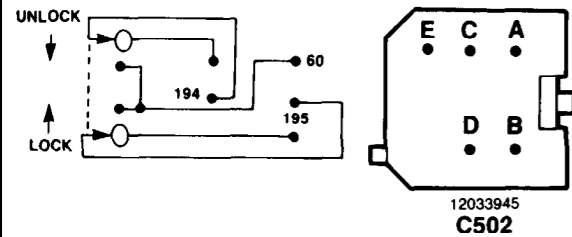

LH POWER DOOR LOCK MOTOR

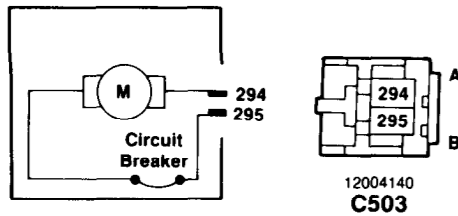

LH POWER MIRROR MOTOR

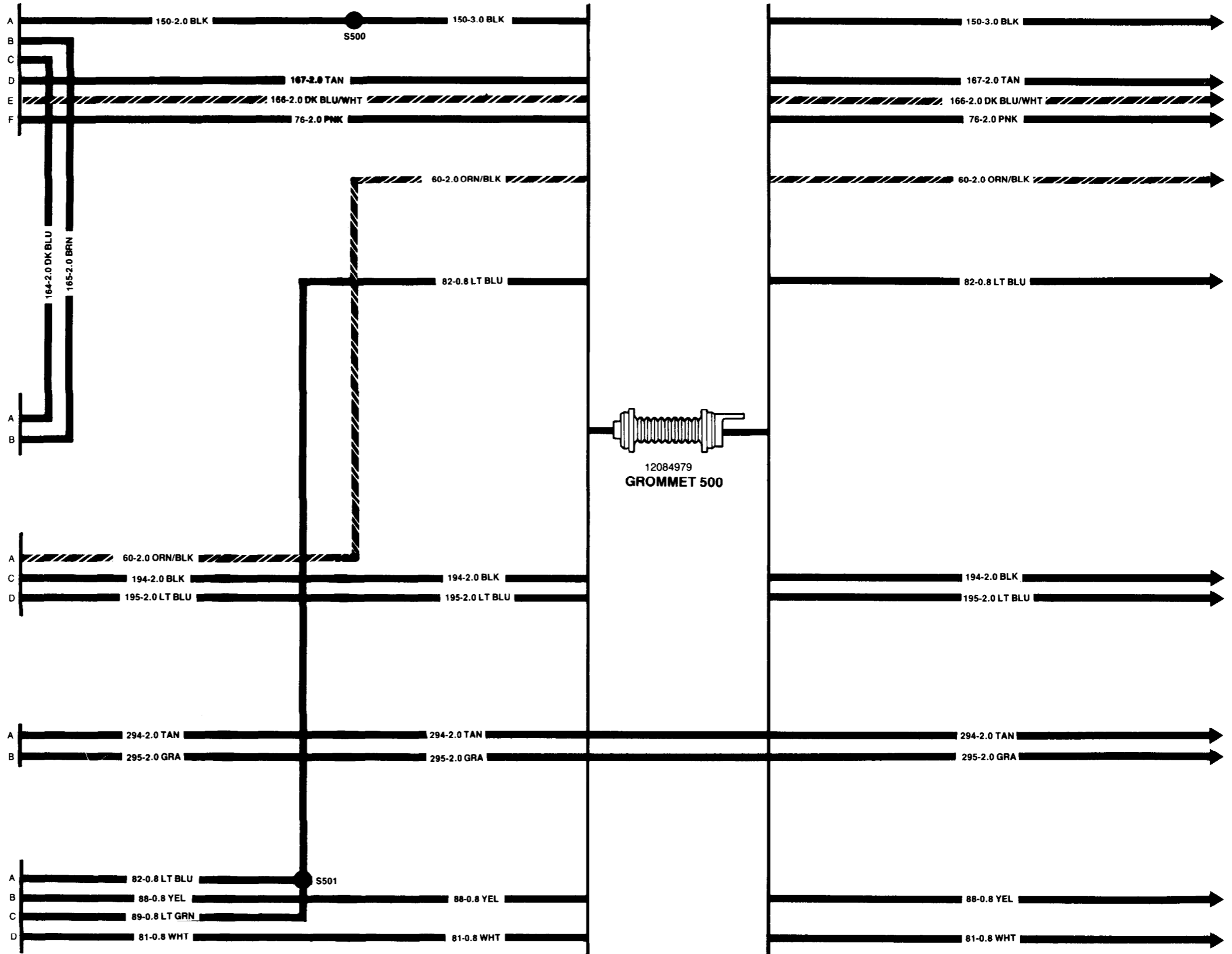
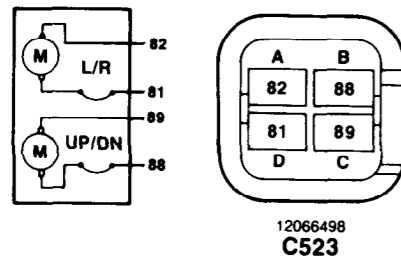

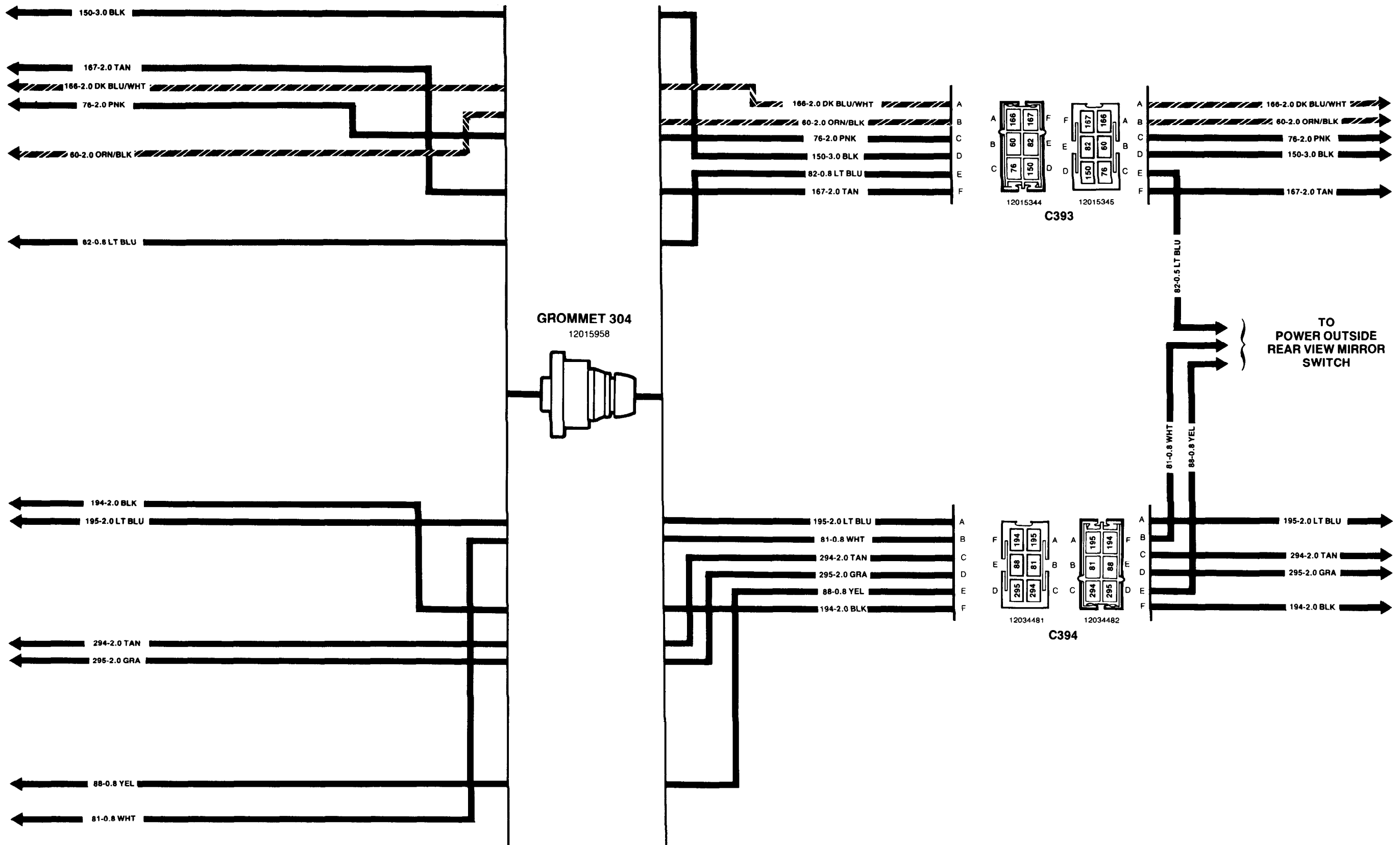

56 LEFT DOOR HARNESS/CROSS-BODY HARNESS (TYPHOON)

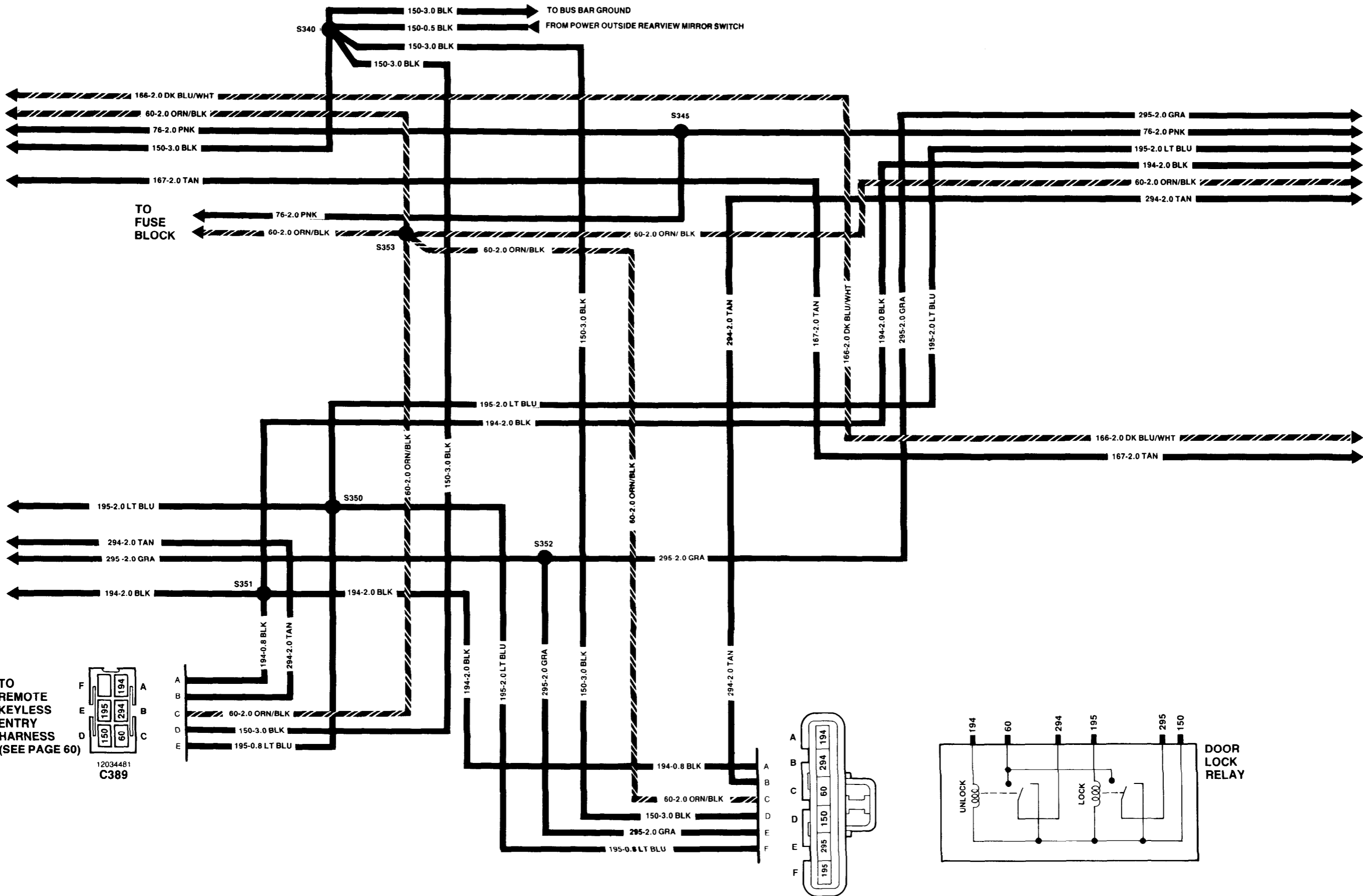

TO REMOTE KEYLESS ENTRY HARNESS (SEE PAGE 60)

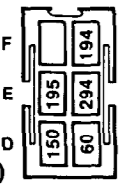

12034481
C389

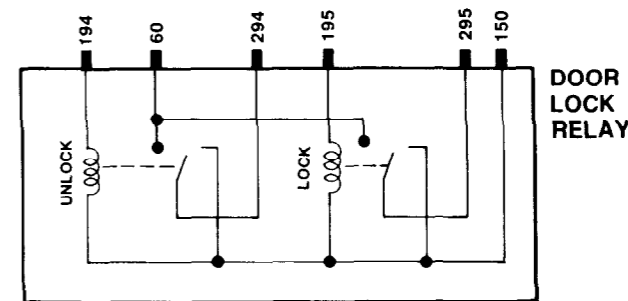
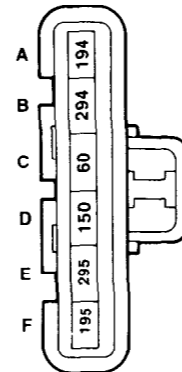

DOOR LOCK RELAY

CROSS-BODY HARNESS (TYPHOON) 57

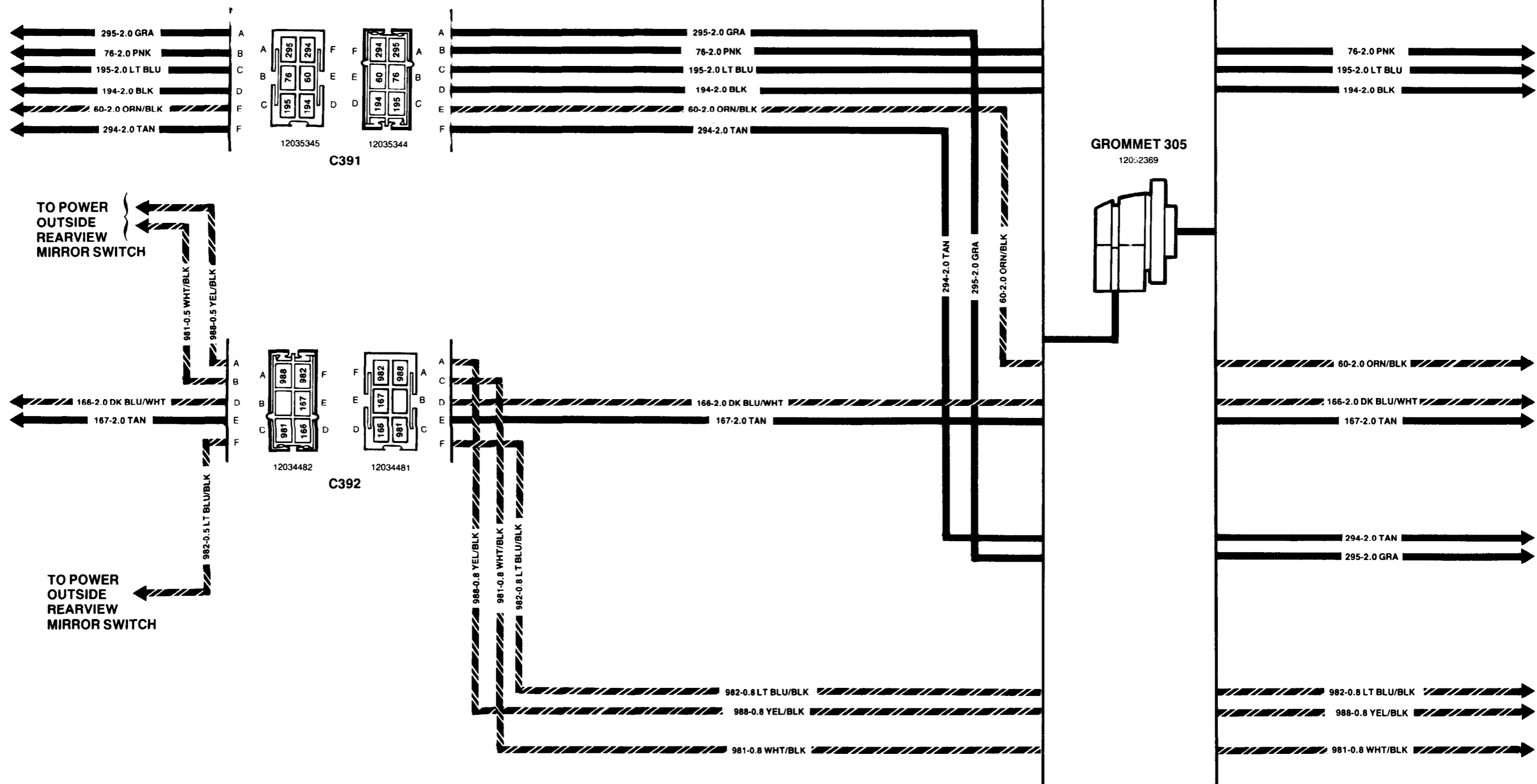

58 CROSS-BODY HARNESS/RIGHT DOOR HARNESS (TYPHOON)

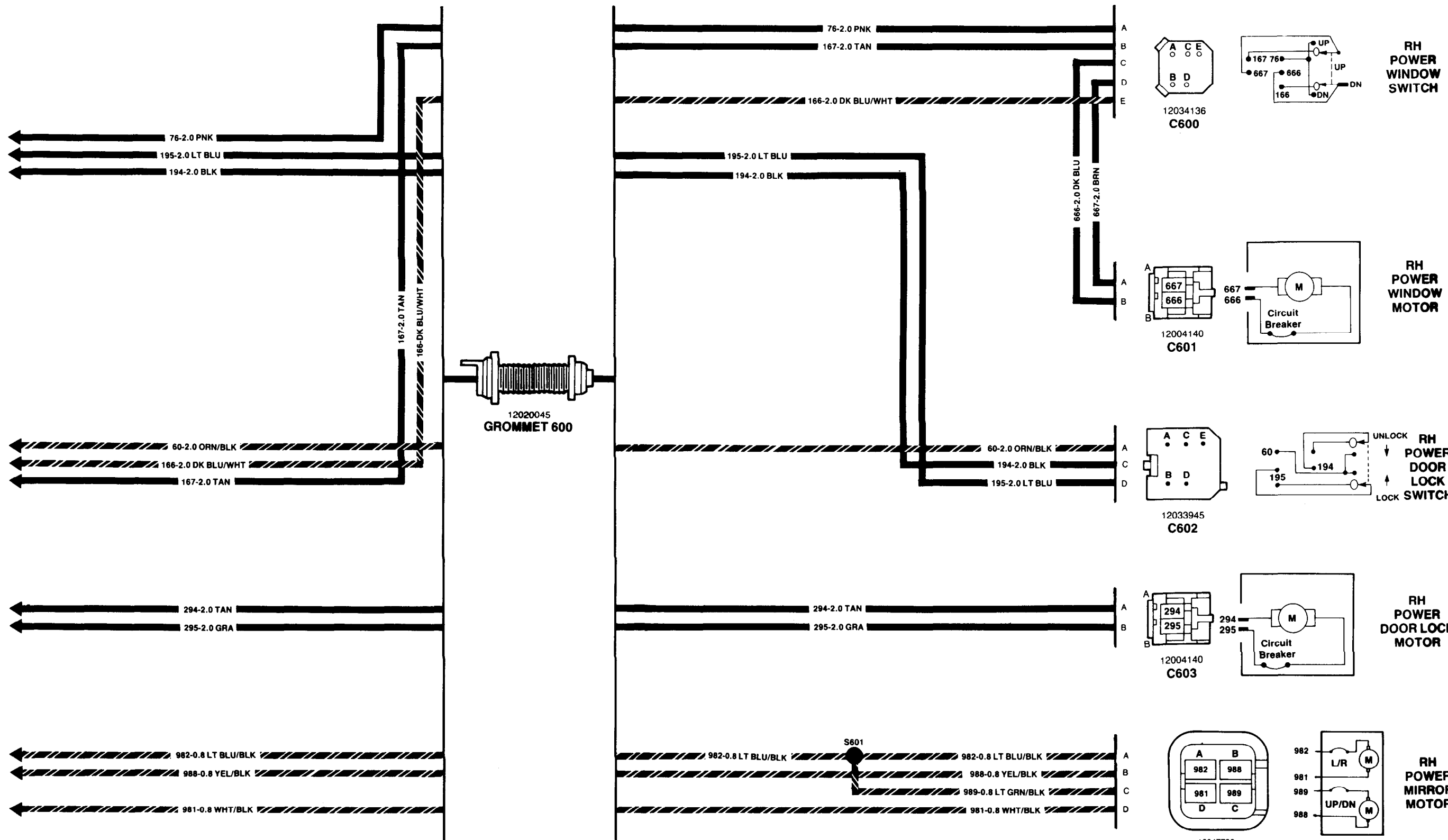

RIGHT DOOR HARNESS (TYPHOON) 59

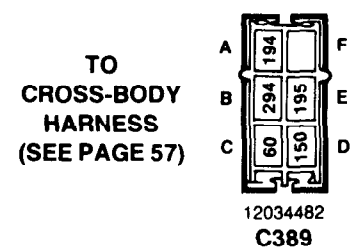
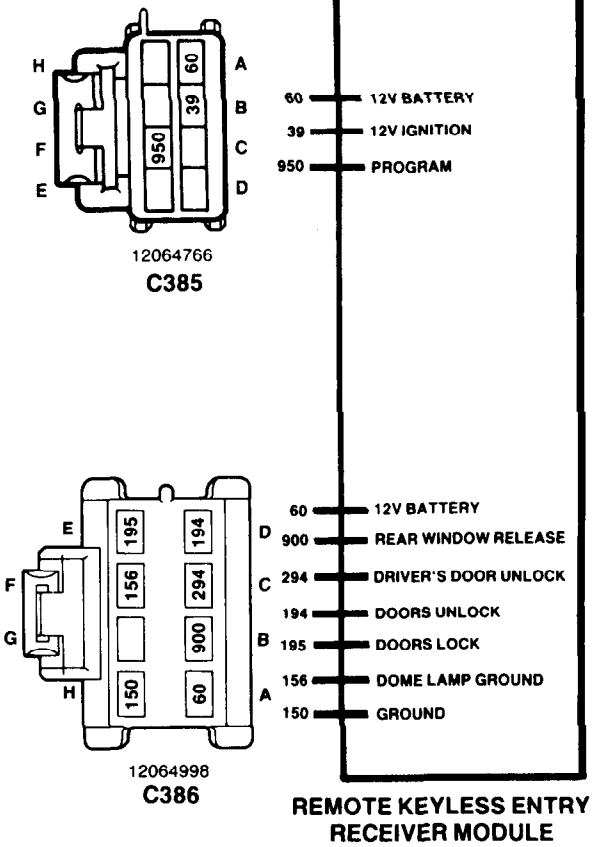
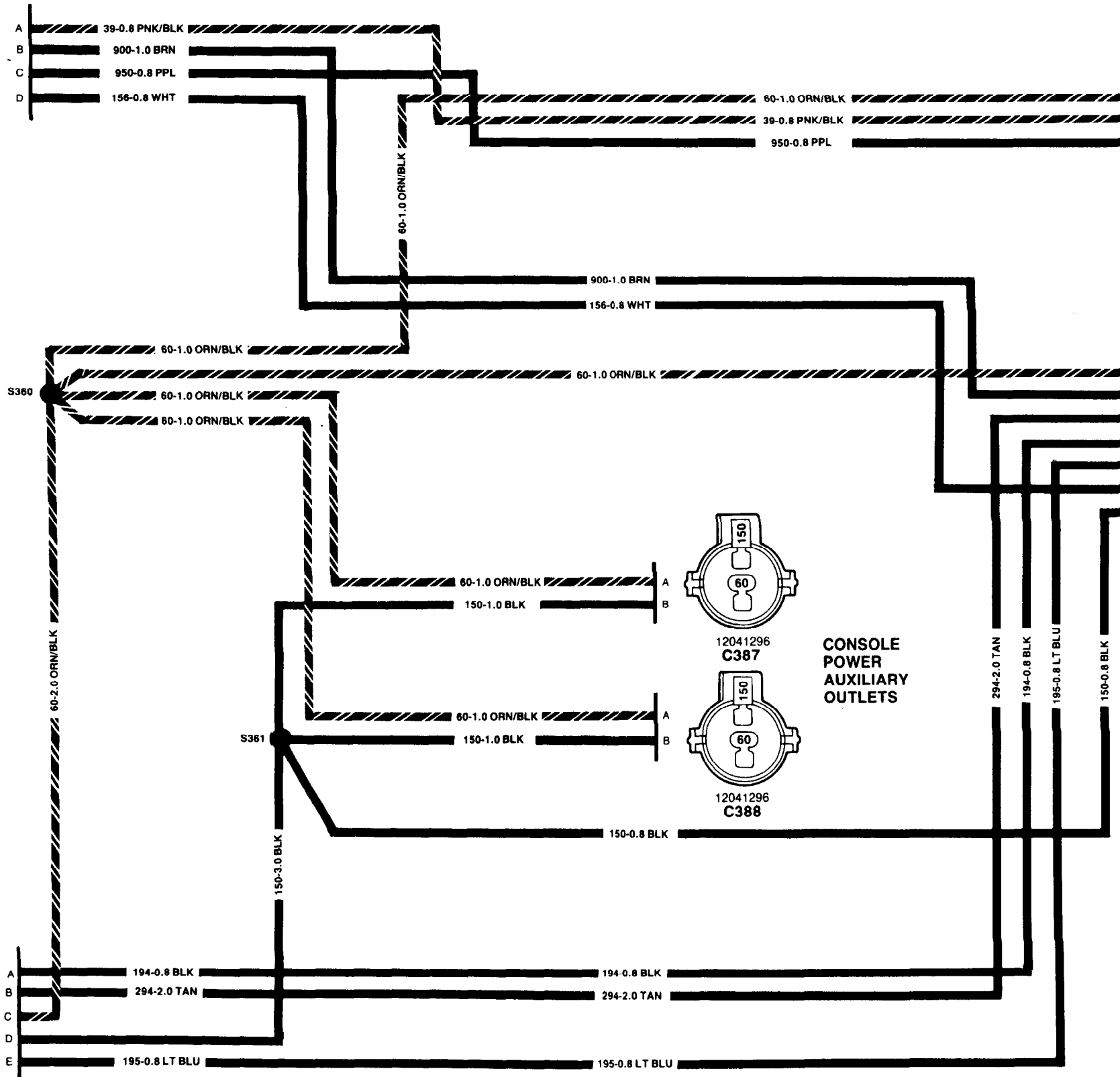
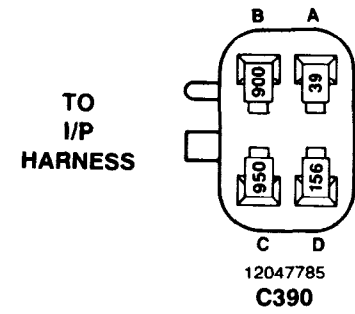

60 REMOTE KEYLESS ENTRY HARNESS (TYPHOON)

TO
C100
(SEE PAGE 49)

